

V1-3

VALVTECHNOLOGIES

Investment Cast Ball Valves ANSI 150-600 1/2" - 2"

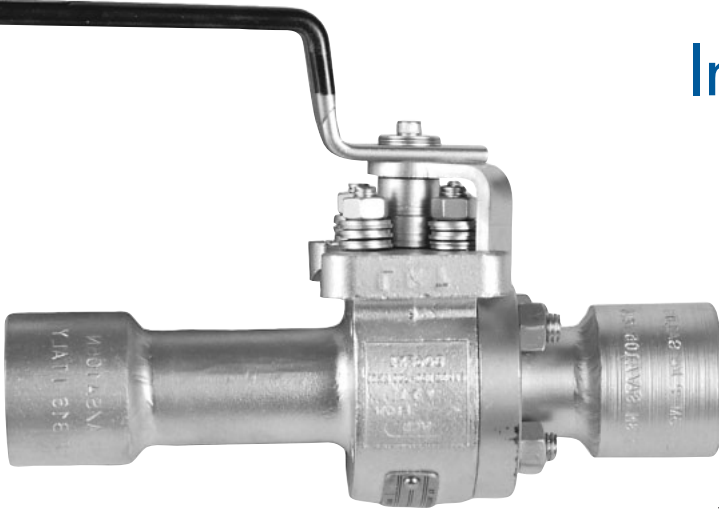

BUTT WELD ENDS

SIZE	A	B	C	D	F	G	J	STEM DIA.	APPROXIMATE WEIGHT (Lb.)	C _v
1/2	6.31	4.59	1.375	3.75	7.12	.63	.84	.50	9	42
3/4	6.31	4.59	1.375	3.75	7.12	.63	1.05	.50	9	30
1	6.31	4.59	1.375	4.20	7.12	.63	1.315	.50	10	20
1	7.75	5.66	1.875	4.06	15	1.06	1.315	.75	21	130
1-1/2	7.75	5.66	1.875	5.38	15	1.06	1.90	.75	24	55
2	13.75	5.66	1.875	5.38	15	1.06	1.90	.75	27	50

SOCKET WELD ENDS

SIZE	A	B	C	D	E	F	G	H	J	STEM DIA.	APPROXIMATE WEIGHT (Lb.)	C _v
1/2	6.31	4.59	1.375	3.75	.855	7.12	.63	.38	1.33	.50	9	42
3/4	8.69	4.59	1.375	4.89	1.065	7.12	.63	.50	1.75	.50	10	42
1	6.25	4.59	1.375	4.89	1.330	7.12	.63	.50	1.75	.50	10	20
1	7.75	5.66	1.875	4.06	1.330	15	1.06	.50	1.90	.75	21	130
1-1/2	10.38	5.66	1.875	5.38	1.93	15	1.06	.75	2.50	.75	24	60
1-1/2	9.50	6.31	2.25	4.60	1.93	18"	1.50	.75	2.92	.75	30	270
2	11.25	5.66	1.875	5.79	2.40	15	1.06	.75	3.00	.75	35	50
2	11.50	7.25	2.88	5.00	2.40	18"	2.13	.75	3.31	1.00	35	135
2	9.50	6.31	2.25	4.60	2.40	18"	1.50	.75	2.92	.75	80	570

* Symmetric about stem centerline.

BILLS OF MATERIAL

ITEM	DESCRIPTION	A105 CARBON STEEL BODY TRIM	316 STAINLESS STEEL BODY TRIM	F22 (2 1/4 Cr.-1 Mo.) ALLOY STEEL	QTY.
		MATERIAL	MATERIAL	MATERIAL	
1	BALL	A182-F316/RAM31	A182-F316/RAM31	410S.S./RAM31	1
2	UPSTREAM SEAT	A182-F316/H.F.	A182-F316/H.F.	A182-F316/H.F.	1
3	BELLEVILLE SPRING	INCONEL 718	INCONEL 718	INCONEL 718	1
4	STEM	316 S.S.	316 S.S.	316 S.S.	1
5	GLAND	A182-F22/H.F.	A182-F22/H.F.	A182-F22/H.F.	1
6	GLAND LOAD SPRING	302 S.S.	302 S.S.	302 S.S.	24
7	GLAND NUT	A194 Gr. 8M	A194 Gr. 8M	A194 Gr. 8M	4
8	GLAND STUD	A193 Gr. B8M	A193 Gr. B8M	A193 Gr. B8M	4
9	END CAP/INTEGRAL SEAT	A105/RAM31	A182 -F316/RAM31	A182 -F22/RAM31	1
10	BODY	A216-WCB	A351 GR CF8M	A217-WC9	1
11	BODY GASKET	17-4	17-4	17-4	1
12	GLAND PACKING	316 S.S./GRAFOIL	316 S.S./GRAFOIL	316 S.S./GRAFOIL	1
13	KEY	STEEL	STEEL	STEEL	2
15	DRIVE SLEEVE	4130	4130	4130	1
16	HANDLE	STEEL	STEEL	STEEL	1
17	BODY STUD	A193 Gr. B8M	A193 Gr. B8M	A193 Gr. B8M	4**
18	BODY NUT	A194 Gr. 8M	A194 Gr. 8M	A194 Gr. 8M	4**

** Quantity is 6 for 1-1/8" Ball
Consult factory for other material options. Also available with NPT ENDS - consult factory.

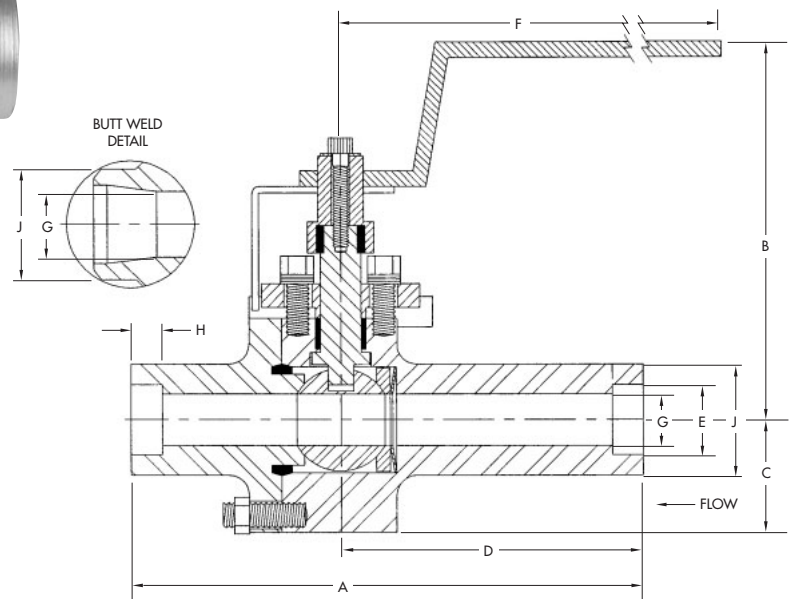

Note: Drawing represents 1/2" and 3/4" valves only.

AVAILABLE BODY OPTIONS:

- Titanium
- Inconel
- Monel
- Nickel
- Duplex Stainless Steel
- 347 Stainless Steel
- 5 Chrome
- 9 Chrome
- WCB
- Hastelloy

Integral Seat, Zero Leakage, Severe Service Metal Seated Ball Valves

V1-3 PRESSURE - TEMPERATURE RATINGS

ANSI 150

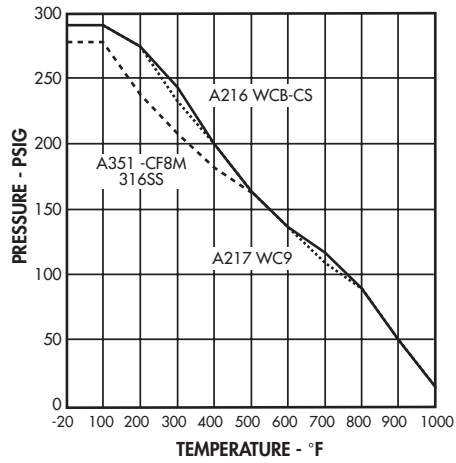

ANSI 300

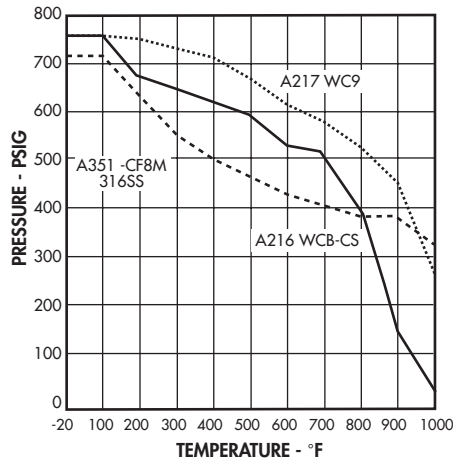

ANSI 600

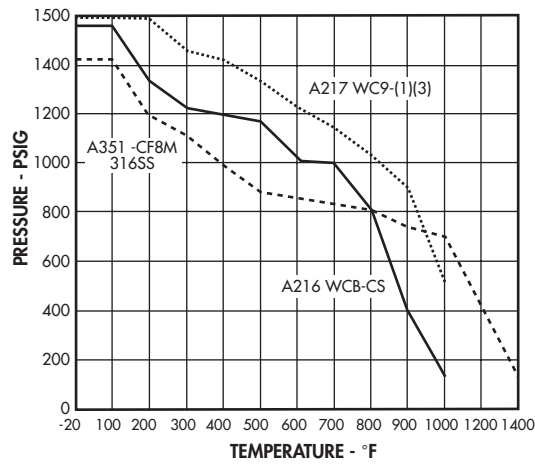

Pressure-Temperature ratings are in accordance with ASME/ANSI B16.34 - 1996

